

Wd 5/5/75 OIC

WIRING DIAGRAMS



TRAINING
SCHOOL

BUSES 8500-8649

I N D E X

<u>Title</u>	<u>Drawing No.</u>	<u>Page No.</u>
Charging Circuit	GU-012062	5
Circuit Breaker Assembly On Equipment Panel	GU-014462	4
Door Control Circuit	GU-122261	6
Equipment Panel Below Driver's Switch Panel	GU-01662	3
Engine Compartment Terminal Block	GU-122761	14
Fluorescent Light Circuit	GU-121961	11
Front Switch Panel Assembly	GU-011062	1
Heater Circuit	GU-122161	7
Heater Circuit 8643 and 8649	GU-122161-A	8
Ignition and Starter Circuit	GU-011462	9
Lamp Data	GU-011762	15
Light Circuits	GU-122061	10
Rear Switch Panel Assembly	GU-011262	2
Shift Circuits	GU-12361	12
Signal Circuits	GU-122961	13
Starting Circuit	GU-011462	8
Switch Panel Assembly, Front	GU-011062	1
Switch Panel Assembly, Rear	GU-011262	2
Wiring Color Codes	GU-11962	16-17-18

GBU/ma
1-29-62

**TRAINING
SCHOOL**

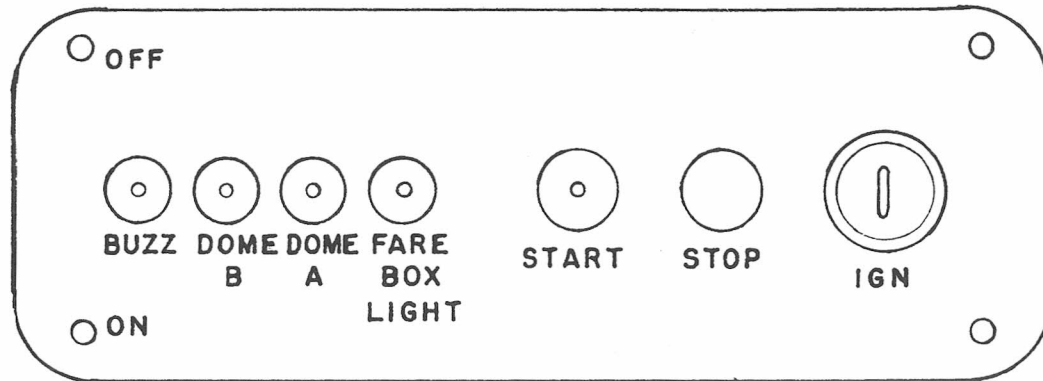

← NAME PLATE

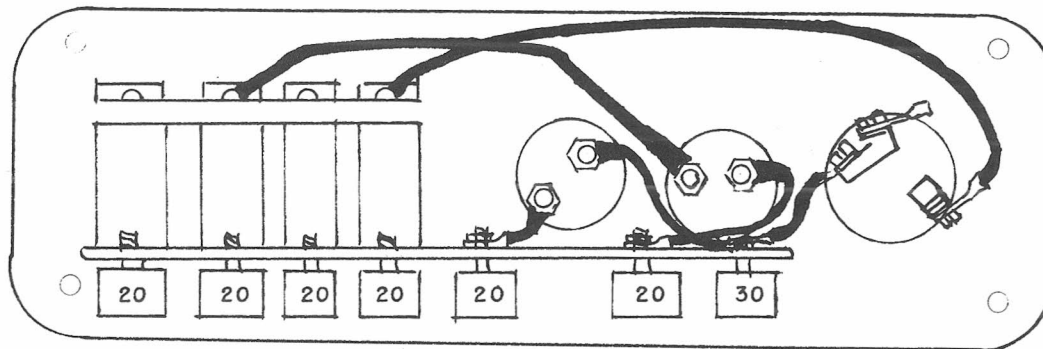
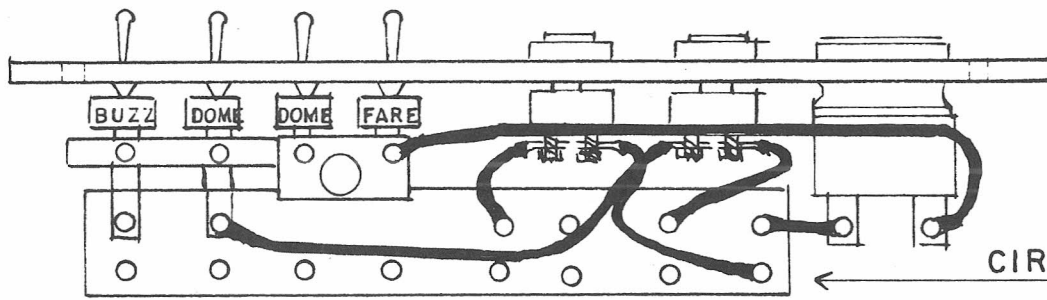

CHICAGO TRANSIT AUTHORITY
 GENERAL SUPERINTENDENT OF ENGINEERING
 EQUIPMENT ENGINEER'S OFFICE
 GU-011062

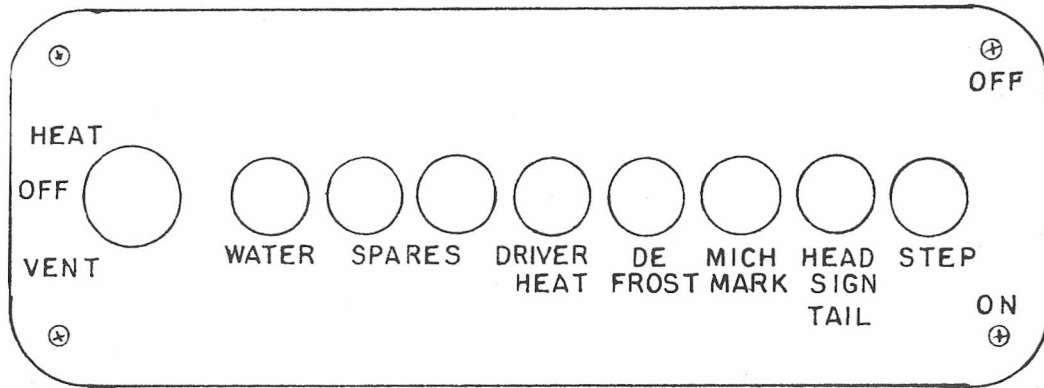

NAME PLATE

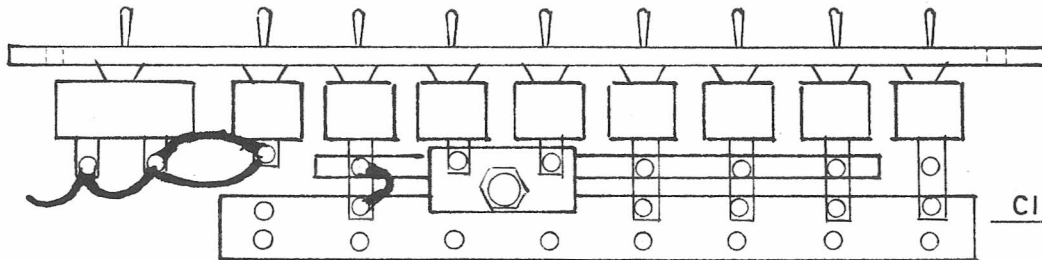

CIRCUIT BREAKER PLATE

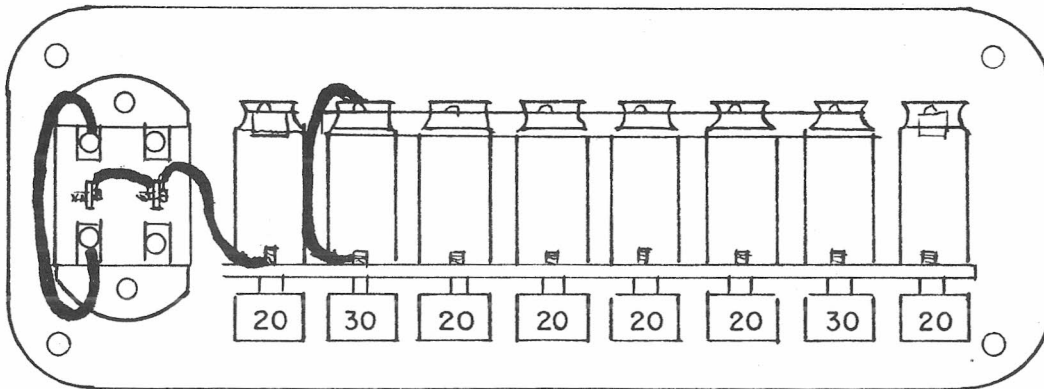

SWITCH MOUNTING PANEL

REAR
SWITCH PANEL ASSY

8500-8649

CHICAGO TRANSIT AUTHORITY
GENERAL SUPERINTENDENT OF ENGINEERING
EQUIPMENT ENGINEER'S OFFICE

GU-011262

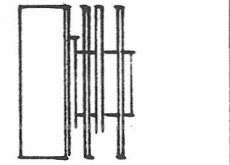
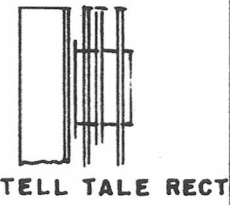
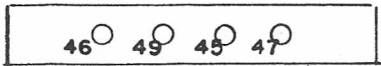
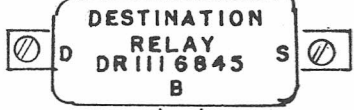
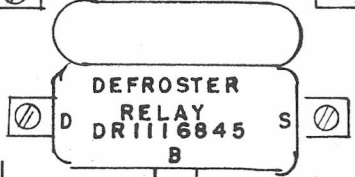
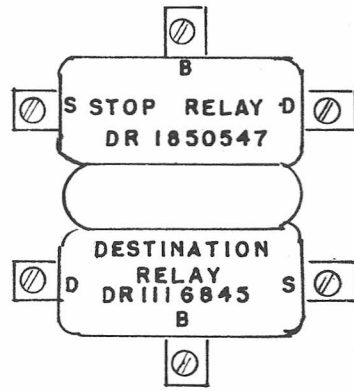
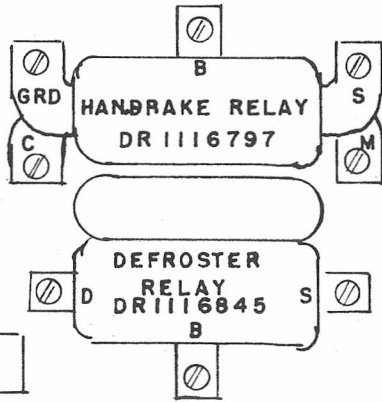
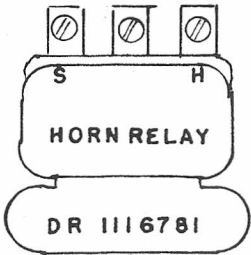
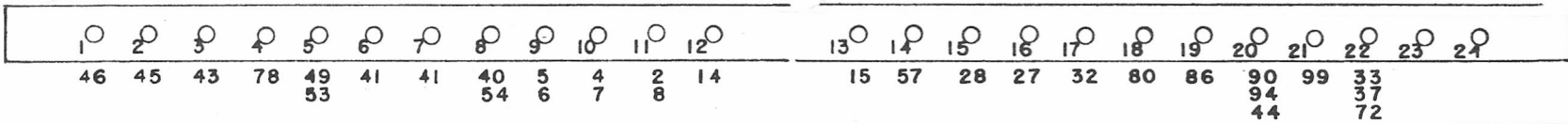

WARNING DIR RECT

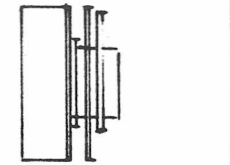

GENERATOR TELL TALE RECT

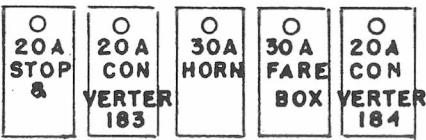
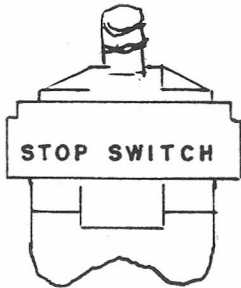
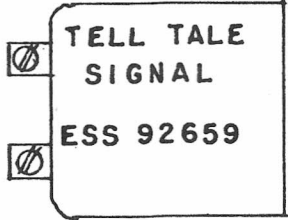
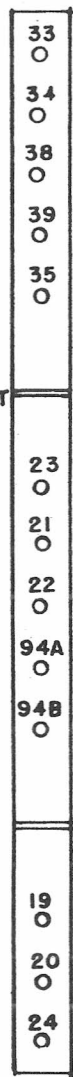

SEE GU-014462

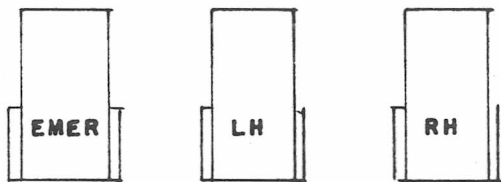

FLASHERS

8500-8649

CHICAGO TRANSIT AUTHORITY
 GENERAL SUPERINTENDENT OF ENGINEERING
 EQUIPMENT ENGINEER'S OFFICE
 GU-01662

EQUIPMENT PANEL BELOW DRIVER'S SWITCH PANEL

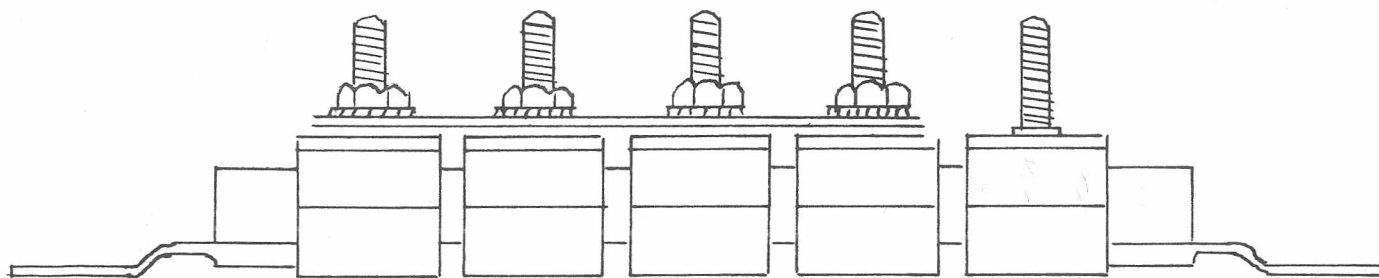
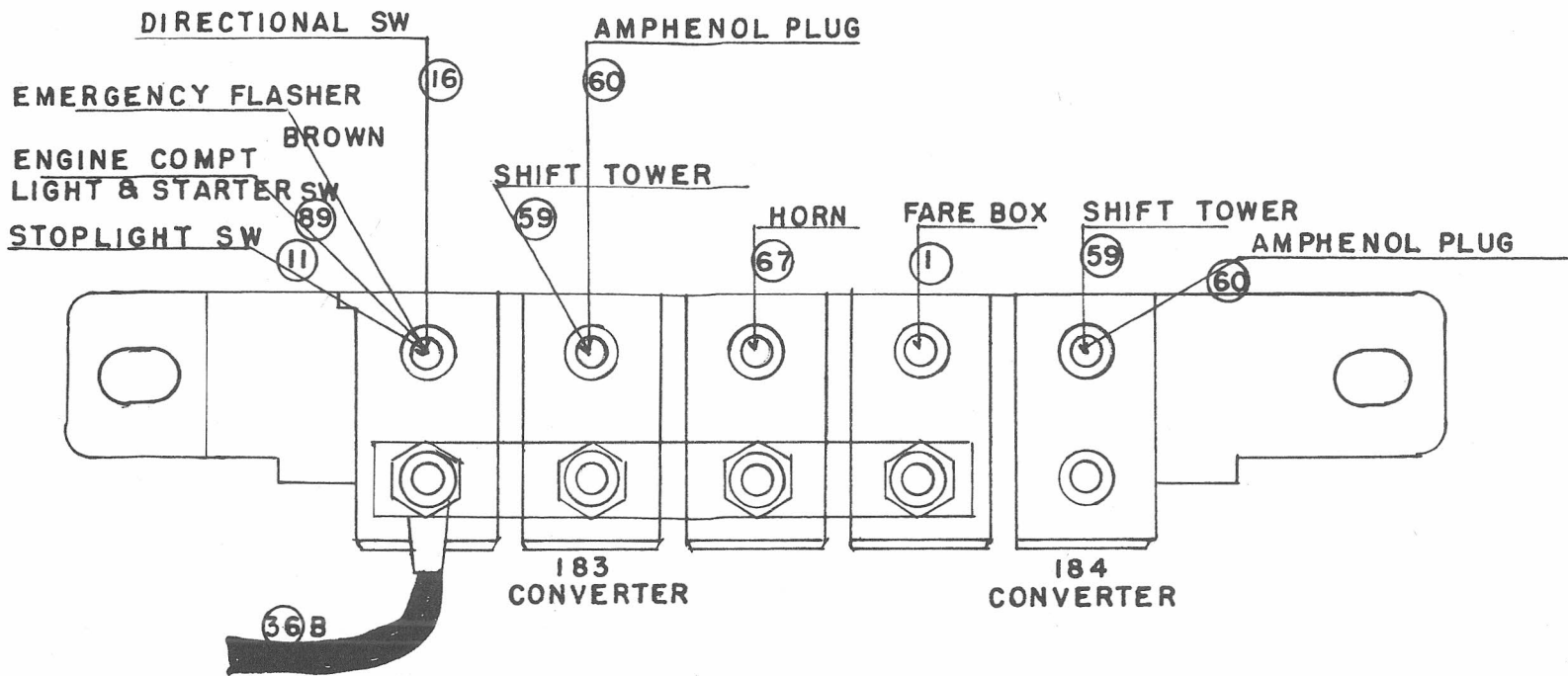

CIRCUIT BREAKER ASSY ON EQUIPMENT PANEL

8500-8649

CHICAGO TRANSIT AUTHORITY
 GENERAL SUPERINTENDENT OF ENGINEERING
 EQUIPMENT ENGINEER'S OFFICE
 GU-014462

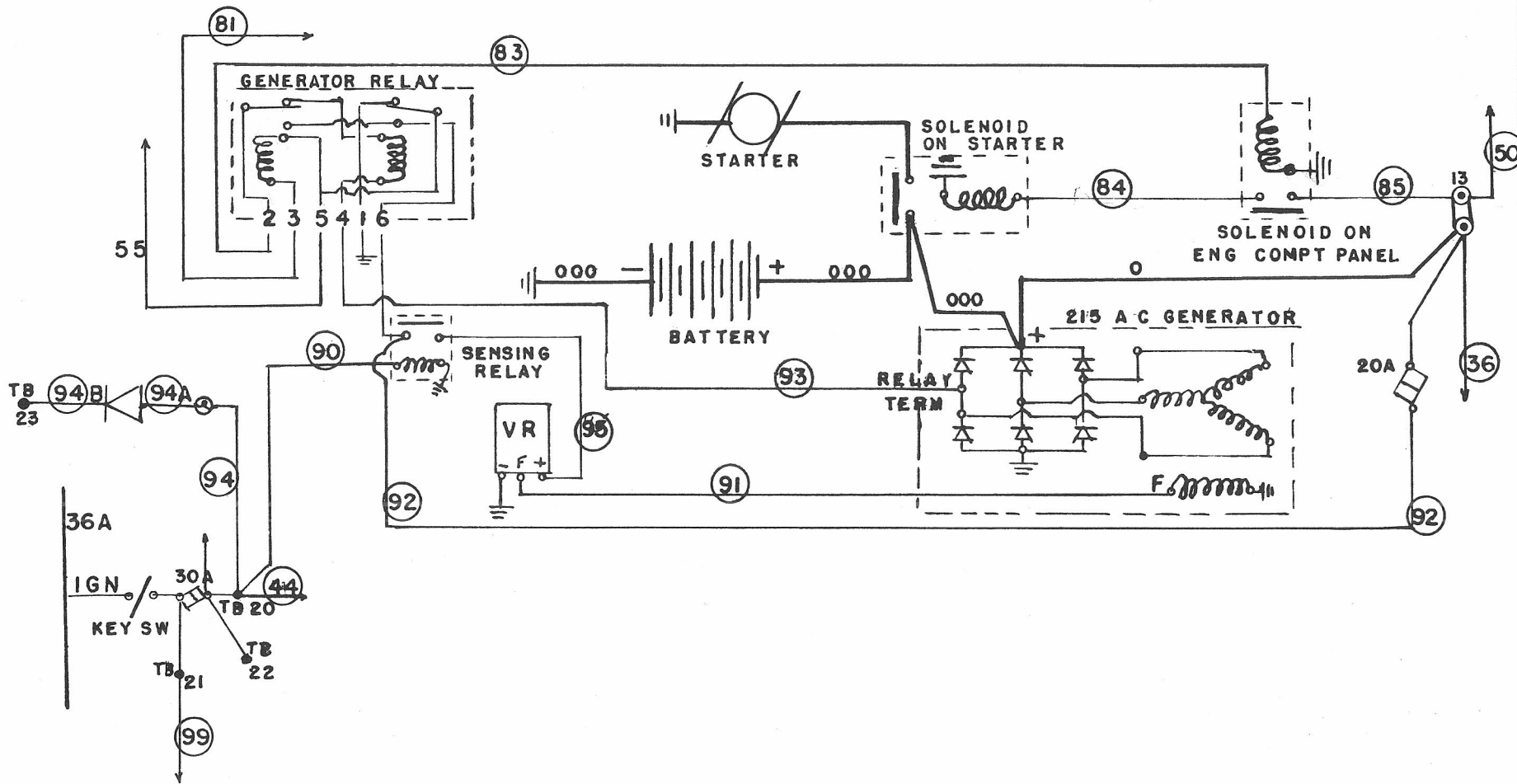

CHARGING CIRCUIT
8500-8649

● TERMINAL BLOCK UNDER SWITCH PANEL

⊙ ENGINE COMPARTMENT TERMINAL BLOCK

CHICAGO TRANSIT AUTHORITY
GENERAL SUPERINTENDENT OF ENGINEERING
EQUIPMENT ENGINEER'S OFFICE

GU-012062

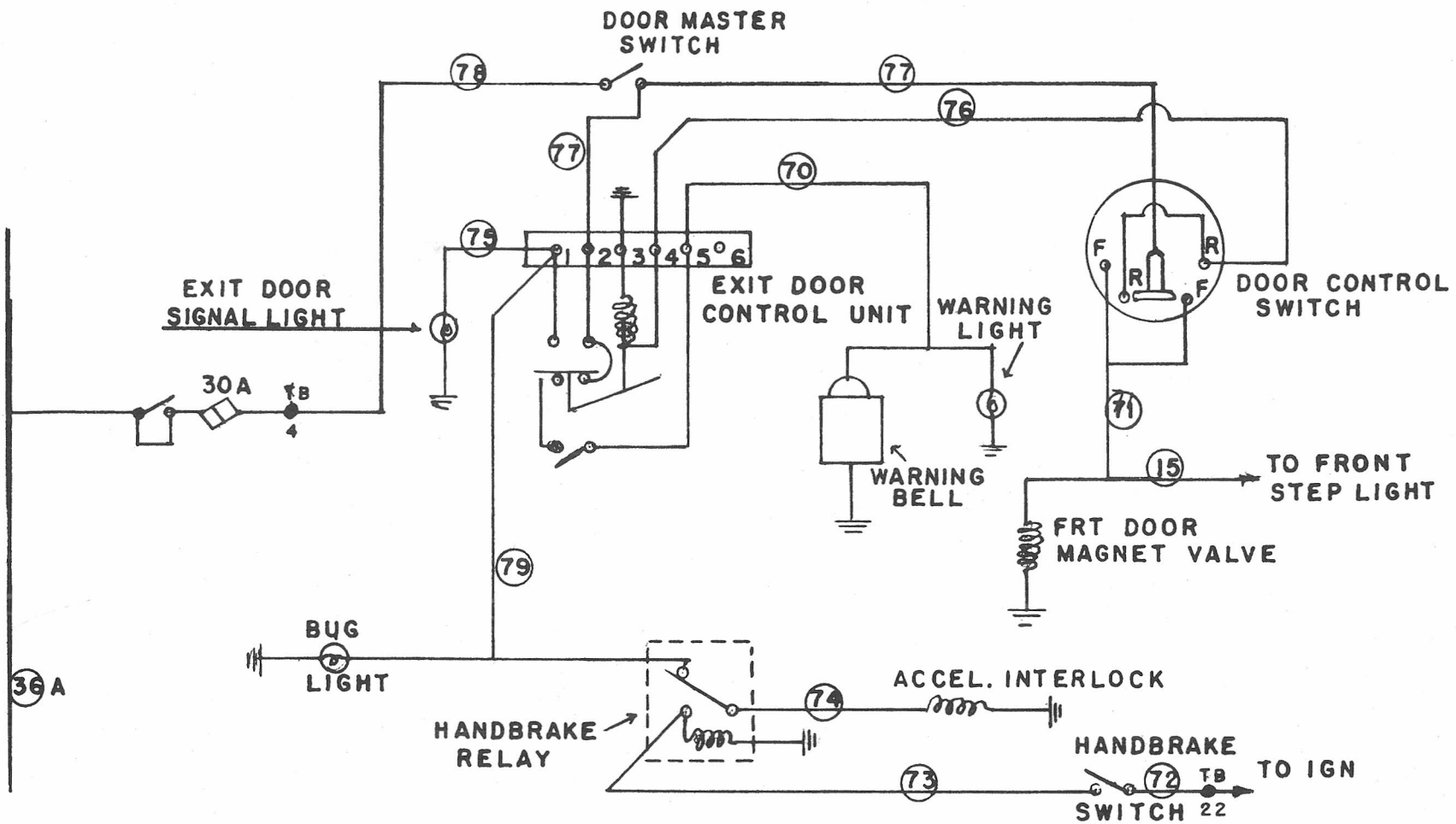

• TERMINAL BLOCK UNDER SWITCH PANEL

DOOR CONTROL CIRCUIT
8500-8649

CHICAGO TRANSIT AUTHORITY
GENERAL SUPERINTENDENT OF ENGINEERING
EQUIPMENT ENGINEER'S OFFICE
GU-122261

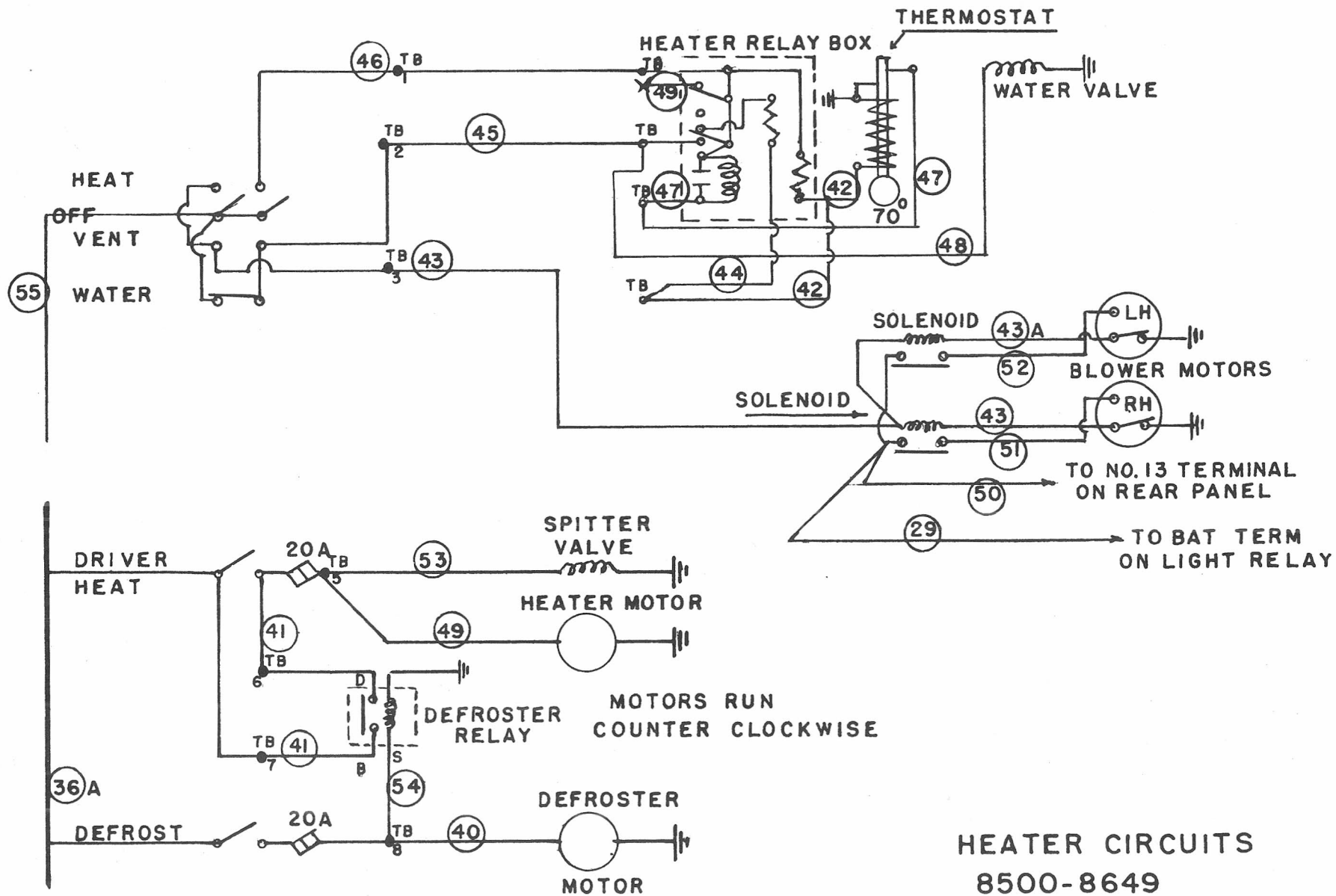

**HEATER CIRCUITS
8500-8649**

• TERMINAL BLOCK UNDER SWITCH PANEL

CHICAGO TRANSIT AUTHORITY
GENERAL SUPERINTENDENT OF ENGINEERING
EQUIPMENT ENGINEER'S OFFICE
GU-122161

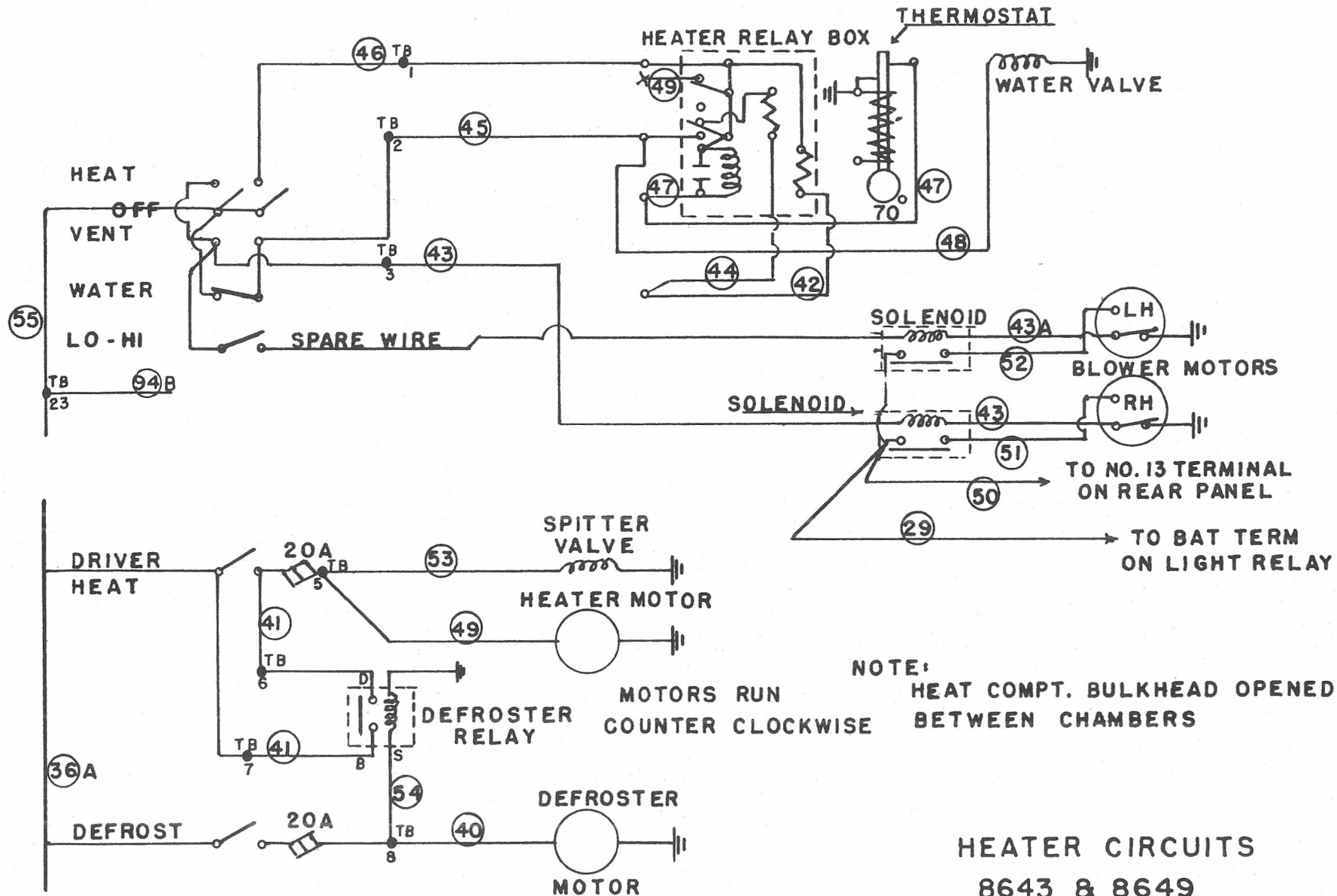

• TERMINAL BLOCK UNDER SWITCH PANEL

CHICAGO TRANSIT AUTHORITY
GENERAL SUPERINTENDENT OF ENGINEERING
EQUIPMENT ENGINEER'S OFFICE
GU-122161-A

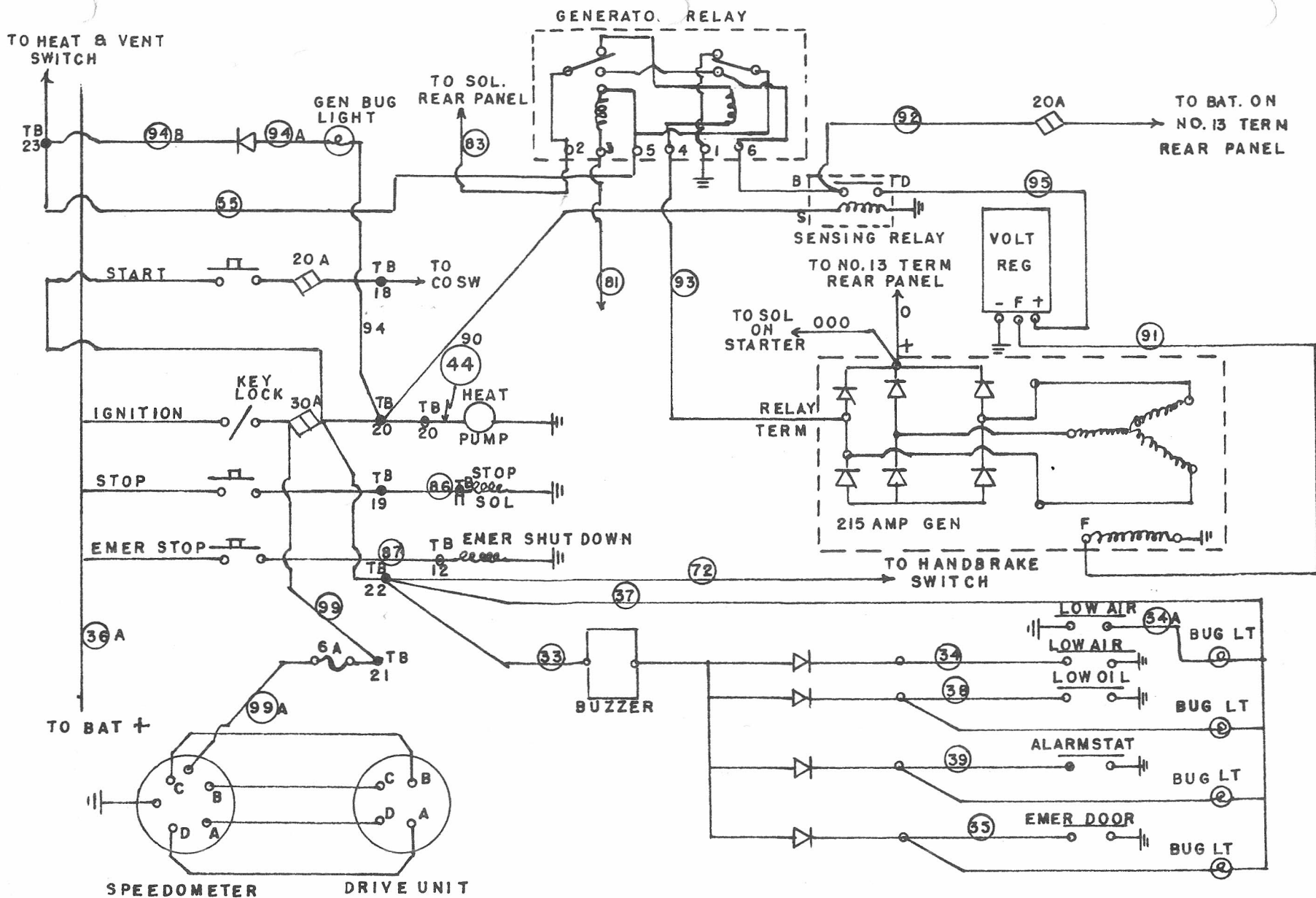

IGNITION & STARTER
CIRCUITS

8500-8649

- TERMINAL BLOCK UNDER SWITCH PANEL
- ⊙ TERMINAL BLOCK IN ENGINE COMPARTMENT

CHICAGO TRANSIT AUTHORITY
GENERAL SUPERINTENDENT OF ENGINEERING
EQUIPMENT ENGINEER'S OFFICE

REVISED 4-26-62

GU-011462

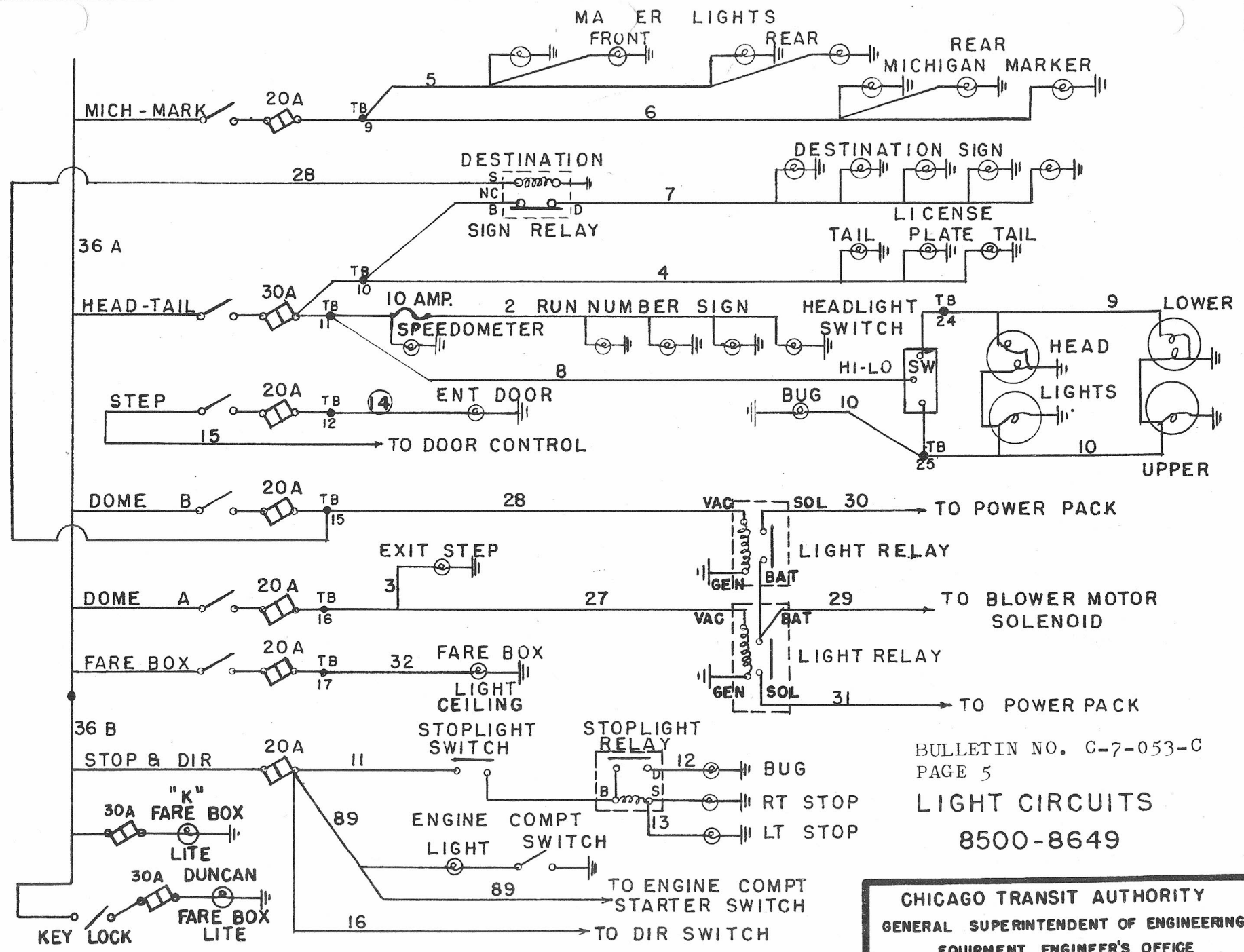

BULLETIN NO. C-7-053-C
PAGE 5

LIGHT CIRCUITS
8500-8649

CHICAGO TRANSIT AUTHORITY
GENERAL SUPERINTENDENT OF ENGINEERING
EQUIPMENT ENGINEER'S OFFICE
GU-122061

● TERMINAL BLOCK UNDER SWITCH PANEL
REVISED 8-30-68, RUN NUMBER SIGN BOX, 10 AMP. FUSE ADDED PER ENGINEERING
MOD. BULL. NO. C-7-053

REVISION "B" 2-24-71
"K" & DUNCAN FARE BOX LIGHT CIRCUIT ADDED

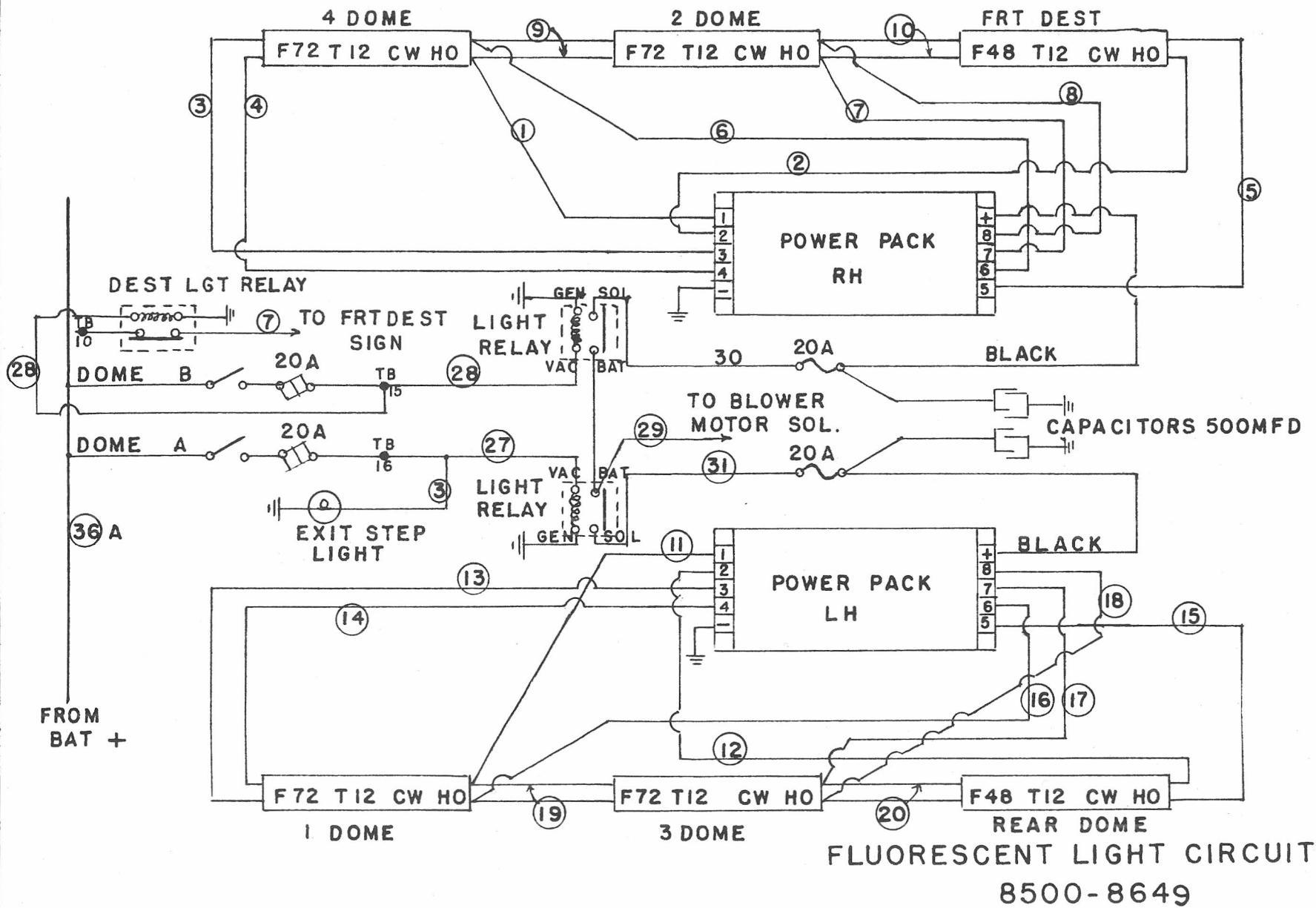

● TERMINAL BLOCK UNDER SWITCH PANEL

CHICAGO TRANSIT AUTHORITY
GENERAL SUPERINTENDENT OF ENGINEERING
EQUIPMENT ENGINEER'S OFFICE

GU-121961

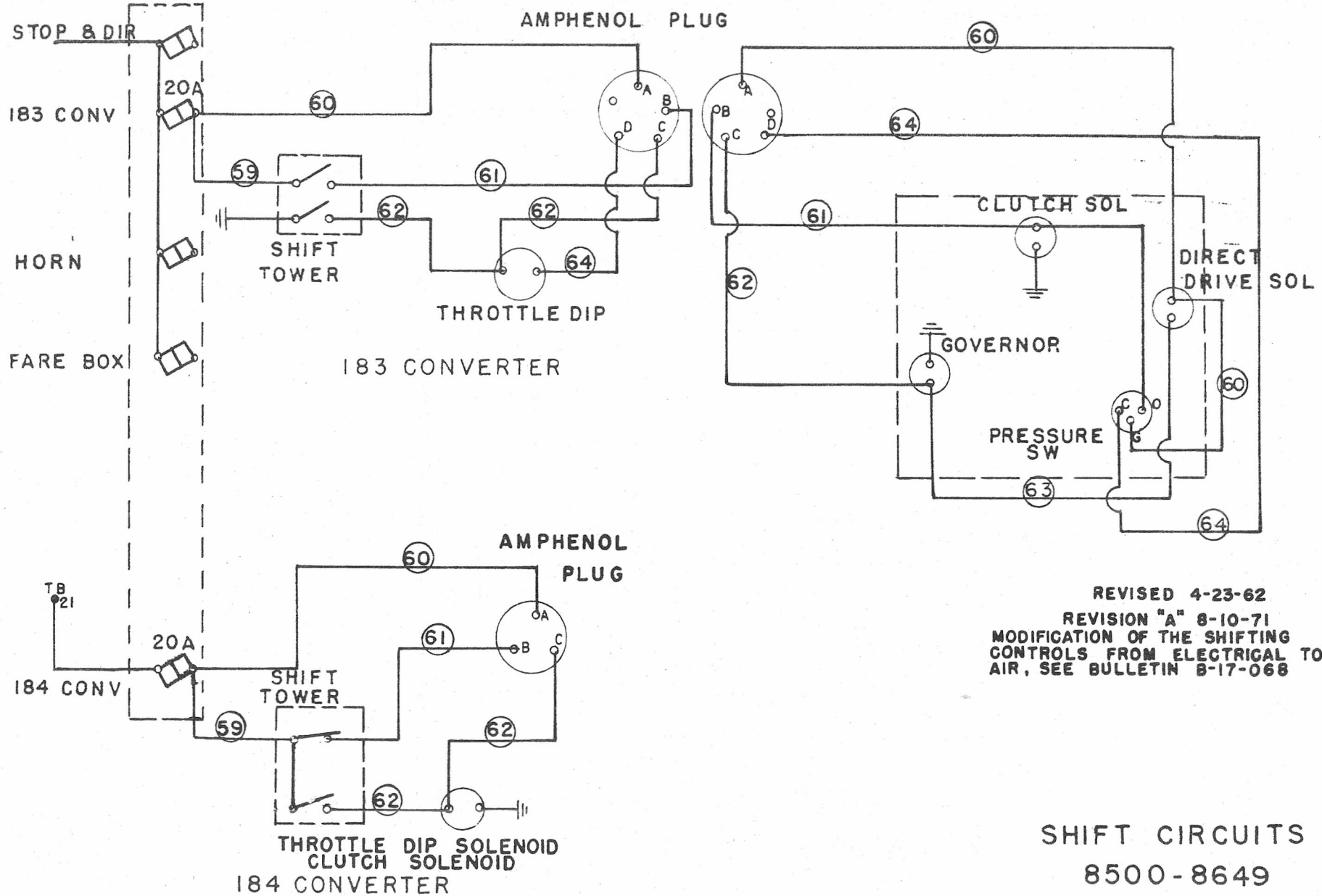

REVISED 4-23-62
 REVISION "A" 8-10-71
 MODIFICATION OF THE SHIFTING
 CONTROLS FROM ELECTRICAL TO
 AIR, SEE BULLETIN B-17-068

SHIFT CIRCUITS
 8500-8649

• TERMINAL BLOCK UNDER SWITCH PANEL

CHICAGO TRANSIT AUTHORITY
 GENERAL SUPERINTENDENT OF ENGINEERING
 EQUIPMENT ENGINEER'S OFFICE
 GU-123161

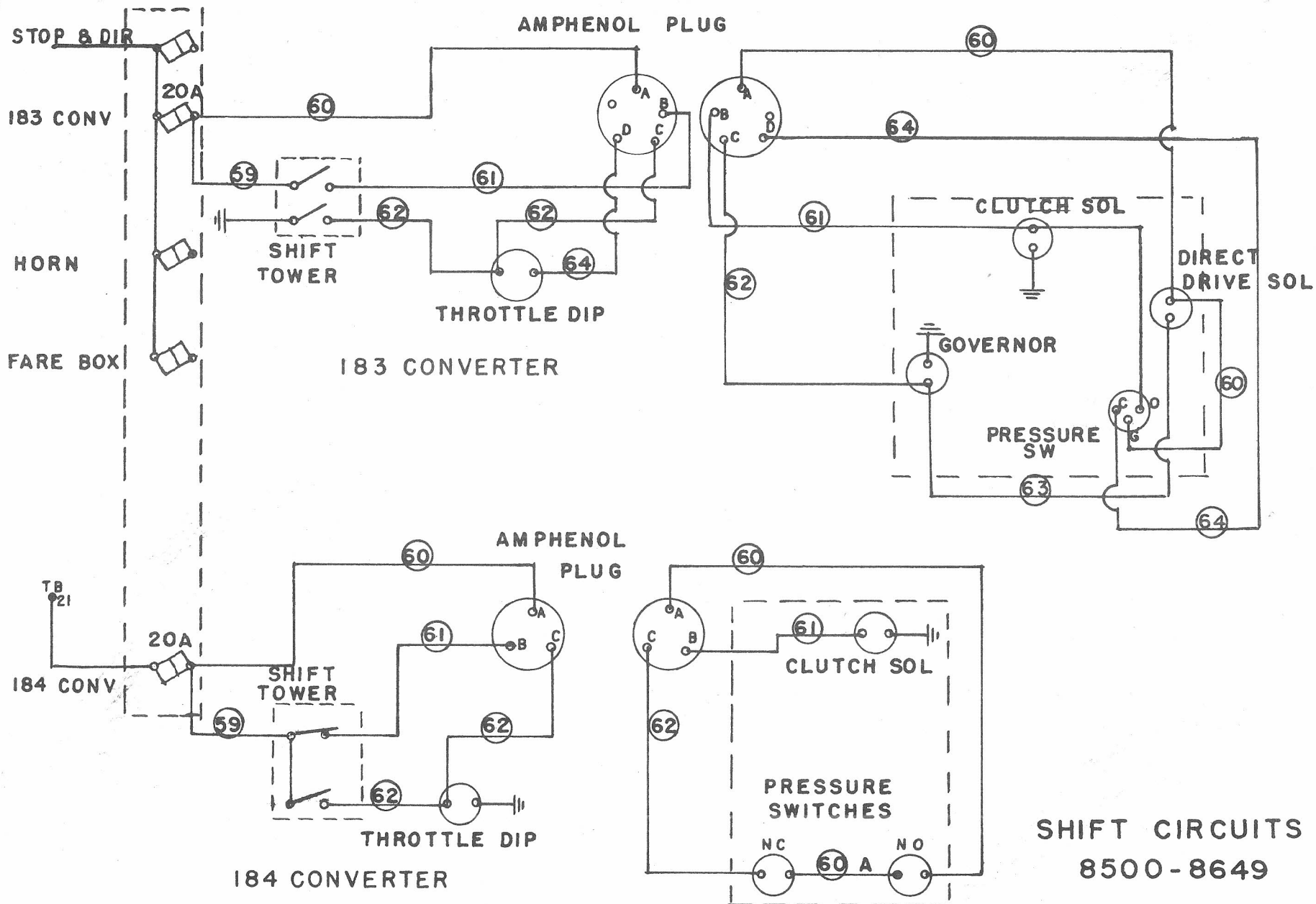

**SHIFT CIRCUITS
8500-8649**

• TERMINAL BLOCK UNDER SWITCH PANEL

**CHICAGO TRANSIT AUTHORITY
GENERAL SUPERINTENDENT OF ENGINEERING
EQUIPMENT ENGINEER'S OFFICE
GU-123161**

REVISED 4-23-62

REVISION "A" 4-20-72
 DIRECTIONAL & EMERGENCY
 SIGNAL CIRCUIT REVISED.

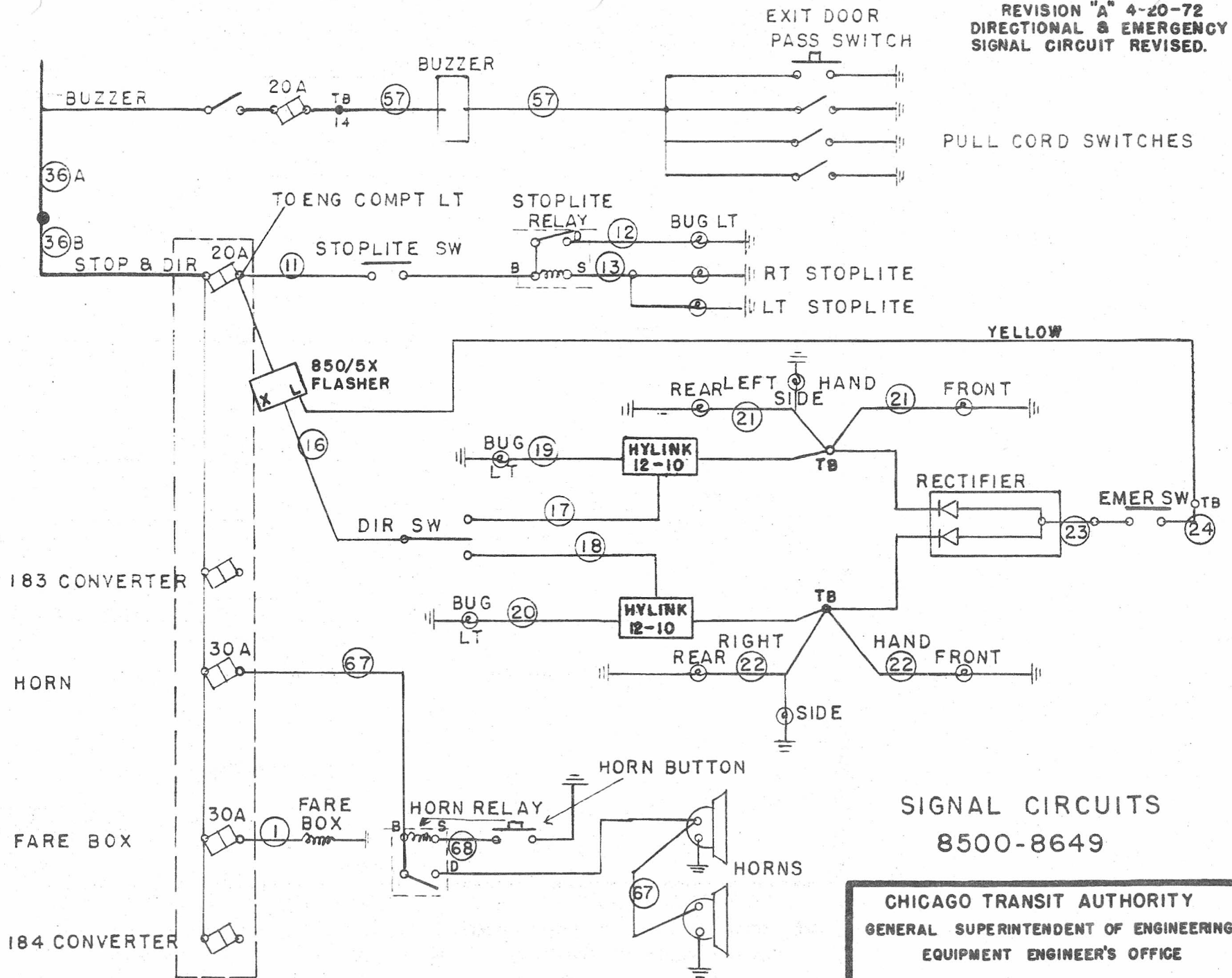

SIGNAL CIRCUITS
 8500-8649

CHICAGO TRANSIT AUTHORITY
 GENERAL SUPERINTENDENT OF ENGINEERING
 EQUIPMENT ENGINEER'S OFFICE

GU-122961

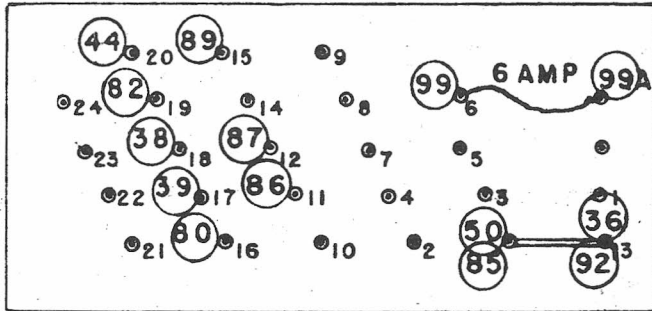

PANEL ASSY
MAIN CABLE

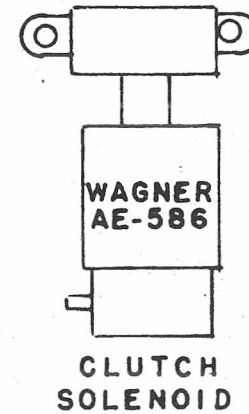
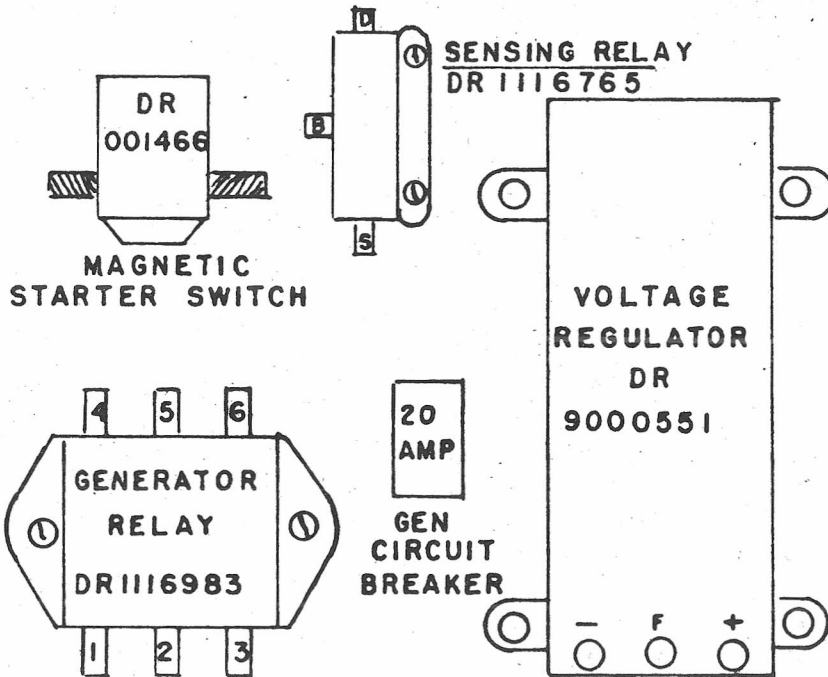
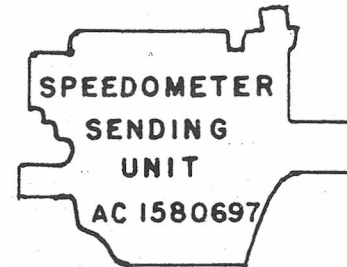

ENGINE COMPARTMENT
TERMINAL BLOCK

⊙ TERMINAL ON REAR PANEL

8500-8649

CHICAGO TRANSIT AUTHORITY
GENERAL SUPERINTENDENT OF ENGINEERING
EQUIPMENT ENGINEER'S OFFICE
GU-122761

BUG LIGHTS 57
DIRECTIONAL LIGHTS,FRT. & REAR 1141
DIRECTIONAL LIGHTS,SIDE 90
ENGINE COMPARTMENT LIGHT 94
EXIT DOOR SIGNAL LIGHT 67
EXIT DOOR WARNING SIGNAL 67
FARE BOX LIGHT 94-IF
FRT. DESTINATION SIGN 94
FRONT MARKER LIGHTS 68
HEADLIGHT, HI-BEAM 4001 OR 4005
HEADLIGHT, LO-BEAM 4002 OR 4006
LICENSE PLATE LIGHT 89
MICHIGAN & REAR MARKER LIGHTS 67

RUN NUMBER SIGN 68
SPEEDOMETER LIGHT 57
STEP LIGHT 94-IF
STOPLIGHTS 1016
TAIL LIGHTS 1016

LAMP DATA

8500-8649

CHICAGO TRANSIT AUTHORITY
GENERAL SUPERINTENDENT OF ENGINEERING
EQUIPMENT ENGINEER'S OFFICE

GU-011762

Wiring Code and Colors

<u>Wire Number</u>	<u>Description</u>	<u>Color Code</u>
1	Fare Box	Black
2	Run Number Sign	Natural
3	Exit Step Light	Natural-Green Tracer
4	Tail-License	Natural-Brown Tracer
5	Markers	Natural-Red Tracer
6	Michigan Markers	Natural-Red Tracer
7	Destination Sign	Natural-Black Tracer
8	Headlight Feed	Natural
9	Low-Beam	Natural-Red Tracer
10	High-Beam	Natural-Black Tracer
11	Stoplight Feed	Natural-Green Tracer
12	Stoplight Bug	Natural-Green Tracer
13	Stoplight to Relay	Natural-Green Tracer
14	Entrance Door Light	Natural-Orange Tracer
15	Entrance Door Light Feed	Natural-Orange Tracer
16	Directional Switch Feed	Black
17	Directional Switch to L.H. Flasher	Red
18	Directional Switch to R.H. Flasher	Green
19	Bug Light Directional L.H.	Pink
20	Bug Light Directional R.H.	Violet
21	Directional Light L.H.	Natural-Blue Tracer
22	Directional Light R.H.	Natural-Yellow Tracer
23	Emergency Switch to Rectifier	Natural-Orange Tracer
24	Emergency Switch to Flasher	Natural-Orange Tracer
25	-----	-----
26	-----	-----
27	Dome Light Relay L.H.	Natural-Green Tracer
28	Dome Light Relay R.H.	Natural-Yellow Tracer
29	Dome Light Relay Feed	Black
30	Dome Light Feed R.H.	Black
31	Dome Light Feed L.H.	Black
32	Fare Box Light	Blue
33	Warning Buzzer	Yellow
34	Low-Air	Yellow
35	Emergency Door	Yellow-Green Tracer
36	Switch Panel Feed	Red
37	Instrument Panel Feed	Yellow-Blue Tracer
38	Low Oil	Yellow-Black Tracer
39	Alarm	Yellow-Red Tracer
40	Defroster	Brown

CHICAGO TRANSIT AUTHORITY
General Superintendent of Engineering
Equipment Engineer's Office

GU 11962

<u>Wire Number</u>	<u>Description</u>	<u>Color Code</u>
41	Defroster Relay	Brown-Yellow Tracer
42	Thermostat	Brown-Yellow Tracer
43	Blower Relays	Brown-Green Tracer
44	Heater Pump	Brown-Blue Tracer
45	Vent Switch to Relay Box	Green
46	Heat Switch to Relay Box	Yellow
47	Thermostat	Brown-Black Tracer
48	Water Valve	Brown
49	Driver Heat	Brown-Yellow Tracer
50	Blower Feed to Solenoid	Black
51	Blower Feed L.H.	Red
52	Blower Feed R.H.	Black
53	Spitter Valve	Red-Blue Tracer
54	Defroster Relay Coil	Brown
55	Heater Switch Feed	Brown-White Tracer
56	-----	-----
57	Buzzer	Yellow-Brown Tracer
58	-----	-----
59	Converter Shift Tower Feed	Black-White Tracer
60	Converter Feed	Black
61	Converter Clutch	Black-White Tracer
62	Converter Throttle Dip	Black-Red Tracer
63	Converter Governor	Black
64	Converter Throttle Dip	Black-Green Tracer
65	-----	-----
66	Fuel Tank	Yellow-Green Tracer
67	Horn	Brown
68	Horn Button	Tan
69	Grounds	White
70	Door Warning Light	Green-Brown Tracer
71	Front Door Magnet Valve	Green-Yellow Tracer
72	Hand Brake Switch to Ignition Switch	Green
73	Hand Brake Switch to Relay	Green
74	Accelerator Interlock	Green-Black Tracer
75	Exit Door Signal	Green-Black Tracer
76	Exit Control to Door Switch	Green-Orange Tracer
77	Master Switch to Door Switch	Green-Red Tracer
78	Master Switch Feed	Green-White Tracer
79	Exit Door Bug	Green-Black Tracer
80	Starter Switch to Cut Out Switch	Red

CHICAGO TRANSIT AUTHORITY
General Superintendent of Engineering
Equipment Engineer's Office

GU 11962

<u>Wire Number</u>	<u>Description</u>	<u>Color Code</u>
81	Relay to Shift Tower Switch	Red-Black Tracer
82	Cut Out Switch to Shift Tower	Red-Black Tracer
83	Generator Relay to Starter Solenoid	Red
84	Starter Solenoid to Starter	Black
85	Post #13 to Starter Solenoid	Black
86	Stop Solenoid	Red-Yellow Tracer
87	Emergency Stop	Red-Green Tracer
88	Jumper: Cut Out Switch to ECS Switch	Red-Blue Tracer
89	Engine Compartment Feed	Red
90	Ignition Switch to Sensing Relay	Orange-Blue Tracer
91	Generator Feed	Orange-Black Tracer
92	Post #6 on Generator Relay	Orange-White Tracer
93	Relay Terminal Generator	Orange-Red Tracer
94	Generator Bug Light	Orange-Blue Tracer
95	Voltage Regulator Plus Terminal	Orange-Green Tracer
96	-----	-----
97	Spare	Blue
98	Spare	Blue
99	Speedometer	Red-White Tracer

Note 1: Natural is a dull white.

Note 2: All these numbers and colors are shown on the Wiring Schematic, 70-1201, Sheet 16, Revision K. If in doubt, check this print.

CHICAGO TRANSIT AUTHORITY
General Superintendent of Engineering
Equipment Engineer's Office

GU 11962

TRAINING
SCHOOL